



UNITED SUPPLY INTERNATIONAL

## 3/4" to 2" Gas Meter Ball Valves



The pressure is on the Valve  
Not on the Pricing



## UNITED SUPPLY INTERNATIONAL

### USI® CLASSIC BALL STYLE GAS METER VALVE

The USI™ ball style gas meter valve in 3/4" through 2" are available with nickel/Chrome plating, a far more durable coating than other cationic electro-coating processes or painting. The 200 psig rated valve provides superior, maintenance free performance at a price that is competitive with grease sealed plug valves.

The USI valve is a full-port ball valve featuring a tamper resistant design with a triple sealed, "blowout-proof" stem. Produced in accordance with all ASME B16.33 standards, the USI ball style meter valve will provide continuous maintenance free service.

- \* **Meets and Exceeds** the requirements specified in ASME B16.33.
- \* **Maximum Pressure Rating** -- 200 psig nominal working pressure. All valves are 100% tested -- 300 psig air and water test in the open and closed positions and 4 psig air and water test in the closed position.
- \* **Dual Virgin EPDM O-Rings on Stem** -- for maintenance-free sealing at normal and cold temperatures.

- \* **Tamper Resistant Design** -- makes the valve nearly impossible to disassemble.
- \* **C37700 Brass Locking Cap and Body** – resists corrosion and is heat resistant

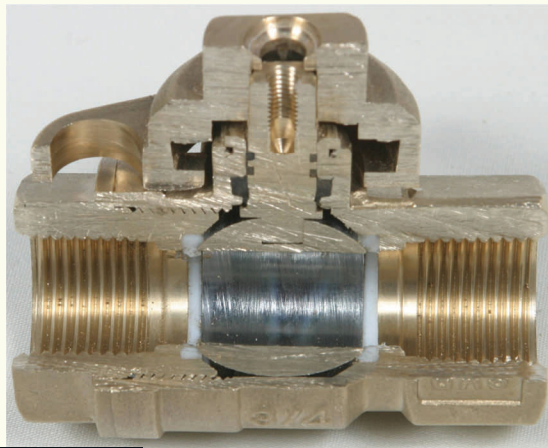

- \* **Gas Compatibility** dry natural or manufactured gas, air vacuum, butane, and propane.
- \* **Full Diameter Round Port** -- provides optimum flow and accepts any style valve changer.



- \* **Blow-out Proof Stem** design is tamperproof. The stem is positively retained by the integral flange on the stem. The stem is made of brass to withstand high temperatures and resist corrosion and has an extra Virgin EPDM thrust washer providing a third sealing on the stem.
- \* **Ball Type Closure** made from nickel/chrome plated brass to provide a positive, long lasting sealing surface. Resilient PTFE primary seals for maintenance-free-sealing at normal and cold temperatures.
- \* **100% Quality tested** to insure the valve is always leak free.



**UNITED SUPPLY INTERNATIONAL**

**CSA Approved  
for both  
The United States and  
Canada**



# USI® 3/4" CLASSIC BALL STYLE GAS METER VALVE—200 PSIG



- \* Meets all applicable parts of ASME B16.33.
- \* Tamper proof design
- \* Brass body
- \* Dual o-ring sealed stem
- \* Integral locking cap
- \* Virgin PTFE seats
- \* Nickel/Chrome plated brass ball
- \* 200 psig nominal working pressure - 300 psig test pressure



Plain Brass  
**GV3BLFF**

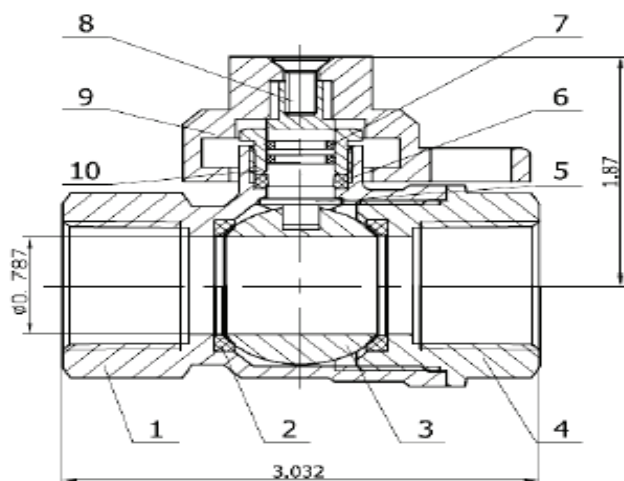

Nickel/  
Chrome Plated  
**GV3BLFF-C**

ITEM	DRAWING NO	DESCRIPTION	MATERIAL	QTY	REMARKS
1	GV3BLFF-1	Body	C37700	1	Sand Polishing Brass or Nickel/Chrome Plated
2	GV3BLFF-2	Rubber Seat	PTFE	2	DK (M111)
3	GV3BLFF-3	Ball	C36000	1	Sand Polishing/Chrome Plating
4	GV3BLFF-4	End Cap	C37700	1	Sand Polishing Brass or Nickel/Chrome Plated
5	GV3BLFF-5	Stem	C36000	1	Brass
6	GV3BLFF-6	Thrust Washer	EPDM	1	Ø0.59XØ0.43X0.14
7	GV3BLFF-7	O-Ring	EPDM	1	Ø0.30XØ0.07
8		Screw Bolt	SUS 305	1	G/T6561-86-M5
9	GV3BLFF-9	Handle	C37700	1	Sand Polishing Brass or Nickel/Chrome Plated
10	GV3BLFF-10	Grand Nut	C36000	1	Brass

# USI® 1" CLASSIC BALL STYLE GAS METER VALVE—200 PSIG



- \* Meets all applicable parts of ASME B16.33.
- \* Tamper proof design
- \* Brass body
- \* Dual o-ring sealed stem
- \* Integral locking cap
- \* Virgin PTFE seats
- \* Nickel/Chrome plated brass ball
- \* 200 psig nominal working pressure - 300 psig test pressure



Plain Brass  
**GV4BLFF**

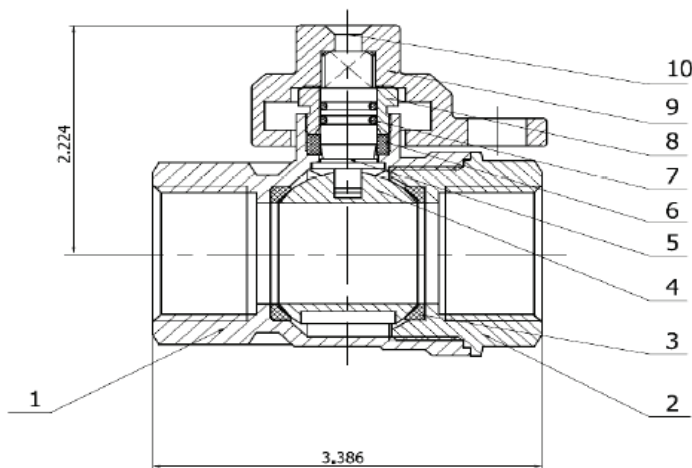

Nickel/  
Chrome Plated  
**GV4BLFF-C**

ITEM	DRAWING NO	DESCRIPTION	MATERIAL	QTY	REMARKS
1	GV4BLFF-1	Body	C37700	1	Sand Polishing Brass or Nickel/Chrome Plated
2	GV4BLFF-2	End Cap	C37700	1	Sand Polishing Brass or Nickel/Chrome Plated
3	GV4BLFF-6	Rubber Seat	PTFE	2	DK (M111)
4	GV4BLFF-3	Ball	C37700	1	Sand Polishing/Chrome Plating
5	GV4BLFF-4	Stem	C36000	1	Brass
6	GV4BLFF-7	Thrust Washer	EPDM	1	Ø0.71XØ0.49X0.2
7	GV4BLFF-8	O-Ring	EPDM	2	Ø0.36XØ0.1
8	GV4BLFF-5	Grand Nut	C36000	1	Brass
9	GV4BLFF-9	Handle	C37700	1	Sand Polishing Brass or Nickel/Chrome Plated
10		Screw Bolt	SUS 305	1	G/T6561-86-M5

# USI® 1 1/4" CLASSIC BALL STYLE GAS METER VALVE—200 PSIG



- \* Meets all applicable parts of ASME B16.33.
- \* Tamper proof design
- \* Brass body
- \* Dual o-ring sealed stem
- \* Integral locking cap



Plain Brass  
**GV5BLFF**



Nickel/Chrome  
Plated  
**GV5BLFF-C**

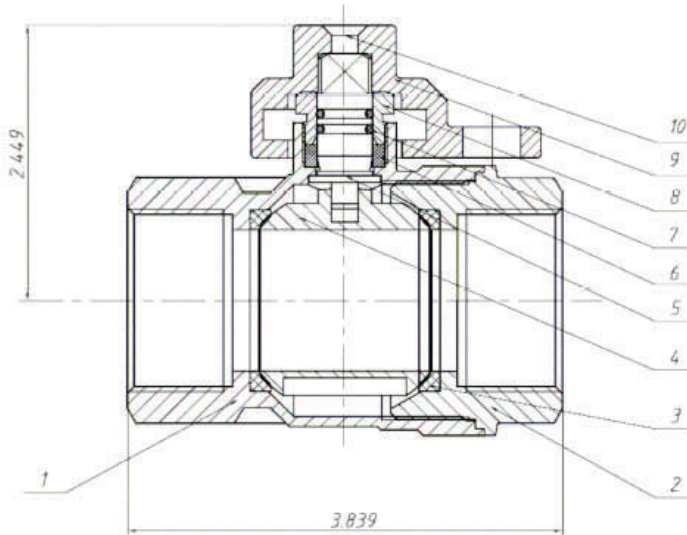

- \* Virgin PTFE seats
- \* Nickel/Chrome plated brass ball
- \* 200 psig nominal working pressure - 300 psig test pressure

ITEM	DRAWING NO	DESCRIPTION	MATERIAL	QTY	REMARKS
1	GV5BLFF-1	Body	C37700	1	Sand Polishing Brass or Nickel/Chrome Plated
2	GV5BLFF-2	End Cap	C37700	1	Sand Polishing Brass or Nickel/Chrome Plated
3	GV5BLFF-6	Rubber Seat	PTFE	2	DK (M111)
4	GV5BLFF-3	Ball	C37700	1	Sand Polishing/Chrome Plating
5	GV5BLFF-4	Stem	C36000	1	Brass
6	GV5BLFF-7	Thrust Washer	EPDM	1	Ø0.71XØ0.49X0.2
7	GV5BLFF-8	O-Ring	EPDM	2	Ø0.36XØ0.1
8	GV5BLFF-5	Grand Nut	C36000	1	Brass
9	GV5BLFF-9	Handle	C37700	1	Sand Polishing Brass or Nickel/Chrome Plated
10		Screw Bolt	SUS 305	1	G/T6561-86-M5

# USI® 1 1/2" CLASSIC BALL STYLE GAS METER VALVE—200 PSIG



- \* Meets all applicable parts of ASME B16.33.
- \* Tamper proof design
- \* Brass body
- \* Dual o-ring sealed stem
- \* Integral locking cap



Plain Brass  
**GV6BLFF**



Nickel/Chrome Plated  
**GV6BLFF-C**

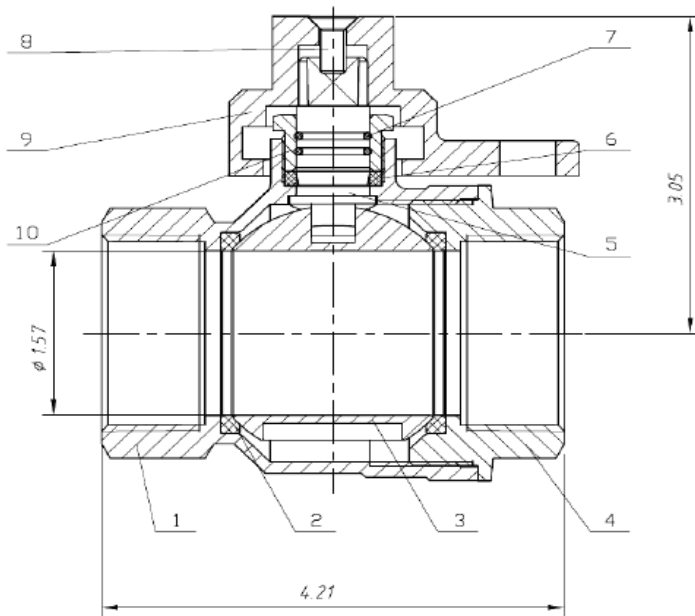

- \* Virgin PTFE seats
- \* Nickel/Chrome plated brass ball
- \* 200 psig nominal working pressure - 300 psig test pressure

ITEM	DRAWING NO	DESCRIPTION	MATERIAL	QTY	REMARKS
1	GV6BLFF-1	Body	C37700	1	Sand Polishing Brass or Nickel/Chrome Plated
2	GV6BLFF-2	Rubber Seat	PTFE	2	DK (M111)
3	GV6BLFF-3	Ball	C36000	1	Sand Polishing/Chrome Plating
4	GV6BLFF-4	End Cap	C37700	1	Sand Polishing Brass or Nickel/Chrome Plated
5	GV6BLFF-5	Stem	C36000	1	Brass
6	GV6BLFF-6	Thrust Washer	EPDM	1	Ø0.89XØ0.67X0.16
7	GV6BLFF-7	O-Ring	EPDM	1	Ø0.55XØ0.07
8		Screw Bolt	SUS 305	1	G/T6561-86-M5
9	GV6BLFF-9	Handle	C37700	1	Sand Polishing Brass or Nickel/Chrome Plated
10	GV6BLFF-10	Grand Nut	C36000	1	Brass

# USI® 2" CLASSIC BALL STYLE GAS METER VALVE—200 PSIG



- \* Meets all applicable parts of ASME B16.33.
- \* Tamper proof design
- \* Brass body
- \* Dual o-ring sealed stem
- \* Integral locking cap



Plain Brass  
**GV7BLFF**

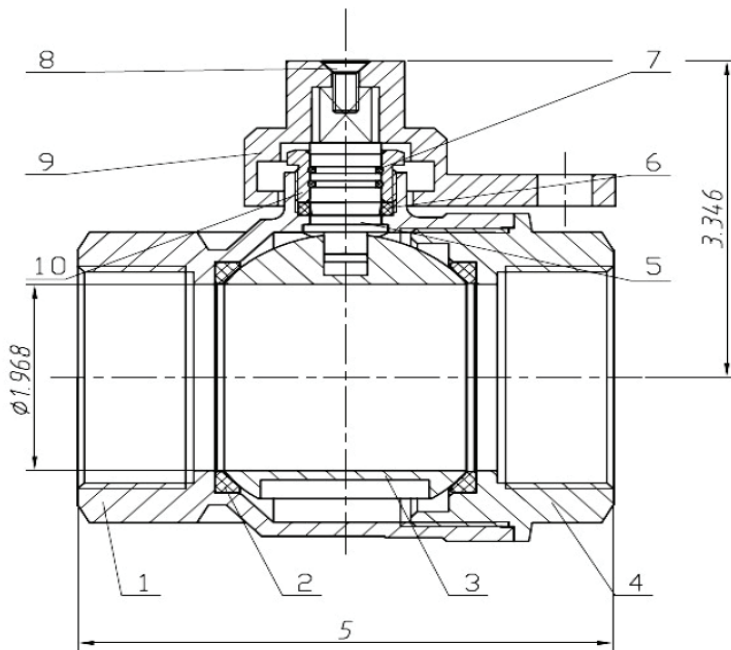

Nickel/Chrome  
Plated  
**GV7BLFF-C**

- \* Virgin PTFE seats
- \* Nickel/Chrome plated brass ball
- \* 200 psig nominal working pressure - 300 psig test pressure

ITEM	DRAWING NO	DESCRIPTION	MATERIAL	QTY	REMARKS
1	GV7BLFF-1	Body	C37700	1	Sand Polishing Brass or Nickel/Chrome Plated
2	GV7BLFF-2	Rubber Seat	PTFE	2	DK (M111)
3	GV7BLFF-3	Ball	C36000	1	Sand Polishing/Chrome Plating
4	GV7BLFF-4	End Cap	C37700	1	Sand Polishing Brass or Nickel/Chrome Plated
5	GV7BLFF-5	Stem	C36000	1	Brass
6	GV7BLFF-6	Thrust Washer	EPDM	1	Ø0.59XØ0.43X0.14
7	GV7BLFF-7	O-Ring	EPDM	1	Ø0.30XØ0.07
8		Screw Bolt	SUS 305	1	GB/T6561-86-MS
9	GV7BLFF-9	Handle	C37700	1	Sand Polishing Brass or Nickel/Chrome Plated
10	GV7BLFF-10	Grand Nut	C36000	1	Brass



# USI® 3/4" DE CLASSIC BALL STYLE GAS METER VALVE—200 PSIG



- \* Meets all applicable parts of ASME B16.33.
- \* Tamper proof design
- \* Brass body
- \* Dual o-ring sealed stem
- \* Integral locking cap



Plain Brass  
**GV13BLFF**  
Nickel/Chrome Plated  
**GV13BLFF-C**

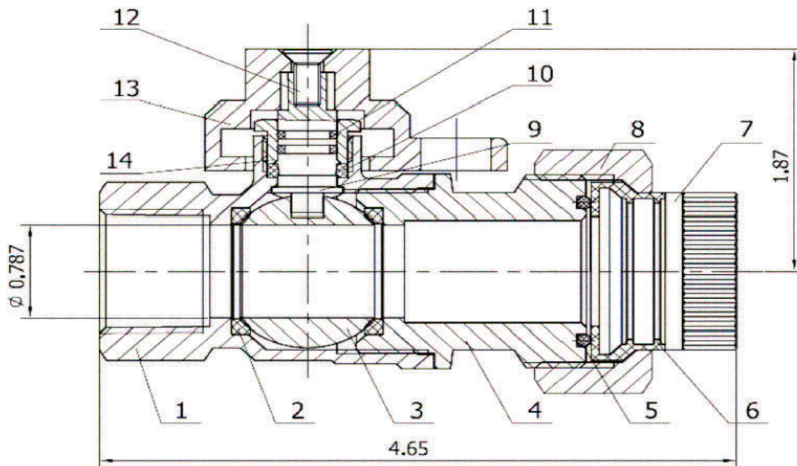

- \* Virgin PTFE seats
- \* Nickel/Chrome plated brass ball
- \* 200 psig nominal working pressure - 300 psig test pressure

ITEM	DRAWING NO	DESCRIPTION	MATERIAL	QTY	REMARKS
1	GV3BLFF-1	Body	C37700	1	Sand Polishing Brass or Nickel/Chrome Plated
2	GV3BLFF-2	Rubber Seat	PTFE	2	DK (M111)
3	GV3BLFF-3	Ball	C36000	1	Sand Polishing/Chrome Plating
4	GV13BLFF-5	End Cap	C37700	1	Sand Polishing Brass or Nickel/Chrome Plated
5	GV13BLFF-1	O-Ring	EPDM	1	Ø0.96XØ0.10
6	GV13BLFF-2	Washer	Nylon	1	Nylon
7	GV13BLFF-3	Connecting Tube	C37700	1	Sand Polishing Brass or Nickel/Chrome Plated
8	GV13BLFF-4	Connecting Nut	C37700	1	Sand Polishing Brass or Nickel/Chrome Plated
9	GV3BLFF-5	Stem	C36000	1	Brass
10	GV3BLFF-6	Thrust Washer	EPDM	1	Ø0.59XØ0.43X0.14
11	GV3BLFF-7	O-Ring	EPDM	2	Ø0.30XØ0.07
12		Screw Bolt	SUS 305	1	G/T6561-86-M5
13	GV3BLFF-9	Handle	C37700	1	Sand Polishing Brass or Nickel/Chrome Plated
14	GV3BLFF-10	Grand Nut	C36000	1	Brass

# USI® 1" DE CLASSIC BALL STYLE GAS METER VALVE—200 PSIG



- \* Meets all applicable parts of ASME B16.33.
- \* Tamper proof design
- \* Brass body
- \* Dual o-ring sealed stem
- \* Integral locking cap



Plain Brass  
**GV14BLFF**

---

Nickel/Chrome Plated  
**GV14BLFF-C**

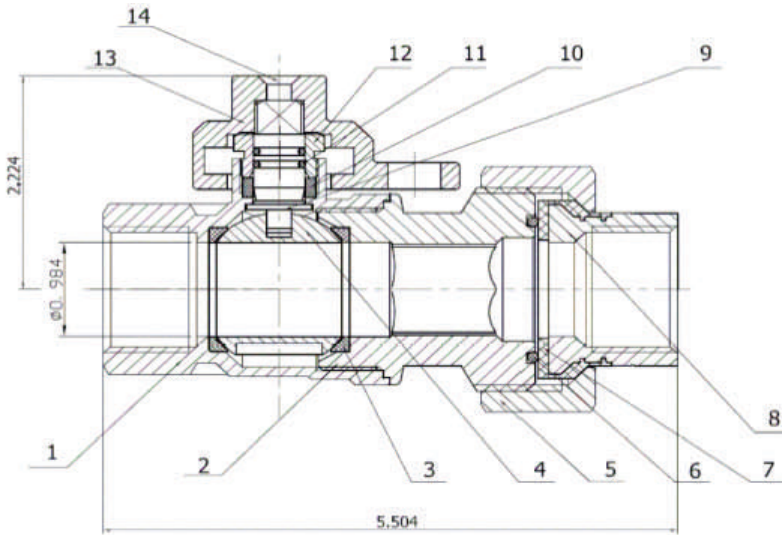

- \* Virgin PTFE seats
- \* Nickel/Chrome plated brass ball
- \* 200 psig nominal working pressure - 300 psig test pressure

ITEM	DRAWING NO	DESCRIPTION	MATERIAL	QTY	REMARKS
1	GV4BLFF-1	Body	C37700	1	Sand Polishing Brass or Nickel/Chrome Plated
2	GV14BLFF-4	End Cap	C37700	1	Sand Polishing Brass or Nickel/Chrome
3	GV4BLFF-6	Rubber Seat	PTFE	2	DK (M111)
4	GV4BLFF-3	Ball	C36000	1	Sand Polishing/Chrome Plating
5	GV14BLFF-3	Connecting Nut	C37700	1	Sand Polishing Brass or Nickel/Chrome Plated
6	GV14BLFF-4	O-Ring	EPDM	1	Ø1.3XØ.1
7	GV14BLFF-5	Washer	Nylon	1	Nylon
8	GV14BLFF-6	Connecting Tube	C37700	1	Sand Polishing Brass or Nickel/Chrome Plated
9	GV4BLFF-4	Stem	C36000	1	Brass
10	GV4BLFF-7	Thrust Washer	EPDM	1	Ø0.73XØ0.55X0.2
11	GV4BLFF-8	O-Ring	EPDM	2	Ø0.43XØ0.07
12	GV4BLFF-5	Grand Nut	C36000	1	Brass
13	GV4BLFF-9	Handle	C37700	1	Sand Polishing Brass or Nickel/Chrome Plated
14		Screw Bolt	SUS 305	1	G/T6561-86-M5



UNITED SUPPLY INTERNATIONAL

Notes:





**WWW.UNITEDSUPPLY.BIZ**



**IMAC Systems, Inc.**  
90 Main Street, PO Box 1605  
Tullytown, PA 19007

1-800-955-4GAS  
Phone: (215) 946-2200  
Fax: (215) 943-2984

[sales@imacsystems.com](mailto:sales@imacsystems.com)

U7S5I1